



CAPITAL

Floor-standing bin

85211

Volume	60 Liter
Compartments	1
Casing material	galvanized steel powder-coated in DB 702
Casing material thickness	1,5 - 2,0 mm 2,00 mm (cover)
Inner liner material	galvanized steel leakproof
Width	470 mm
Depth	320 mm
Height	900 mm
Weight	30,0 kg
Slot size	260 x 120 mm
Accessoires / Options	see FEATURES

AUWEKO GmbH · Dornhofstraße 34 · 63263 Neu-Isenburg
Telefon: +49 6103 804955-0 · Fax: +49 6103 804955-10 · Email: vertrieb@auweko.de · Website: www.auweko.de

Copyright declaration:

All sketches, drawings and electronic information are the property of AUWEKO GmbH in Neu-Isenburg. The use of these documents, hard copies or information is permitted for internal purposes only. Forwarding to third parties is not authorised. Subject to technical alteration. © AUWEKO GmbH, 63263 Neu-Isenburg

CAPITAL

Floor-standing bin 85211

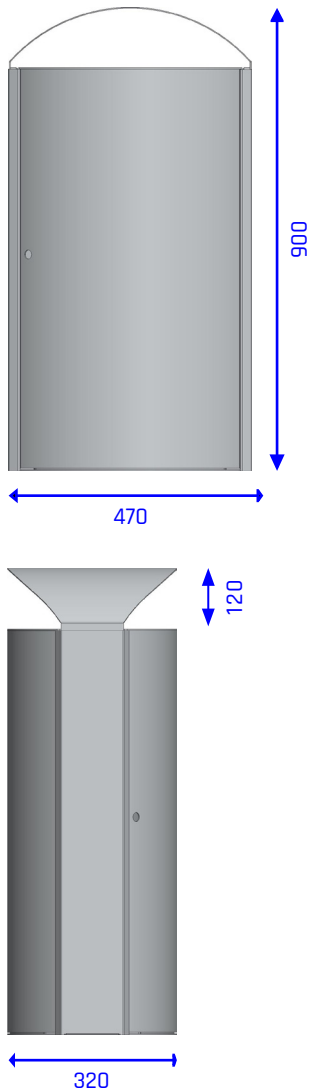

Description: Self-supporting, curved, powder-coated galvanized steel outer walls, connected to stable flat side panels. Curved door with recessed lock (a key is supplied with each container). The door retention profile prevents the hinges from overstretching. A curved cover is firmly connected to the structure. The shape of the cover results in reduced height from two sides. A sturdy insertion ring guides waste into the inner liner.

Safety: The curved cover serves as rain protection without providing a storage area. At the same time, the opening is reduced, which minimizes the disposal of household refuse bags. Snap locks protect the bins against unauthorized access.

Handling: Use the square key to operate (1/4 turn) the embedded snap lock and open the door. Pull out / lift out inner liner respectively remove the bag from the bag holder. The contents are now visible and the waste bag can be replaced as required. The snap lock allows the door to be closed and locked without a key

Cleaning: The powder-coated galvanized steel surface makes the boxes easy to clean and maintain. Commercial care products for powder-coated materials are sufficient.